



**MACK ANTHEM DAYCAB SINGLE TRAILER/  
A-DOUBLE OPTIMISED SPEC**

**BUILT FOR  
PURPOSE**



[MackTrucks.com.au](https://MackTrucks.com.au)

**BORN READY.**

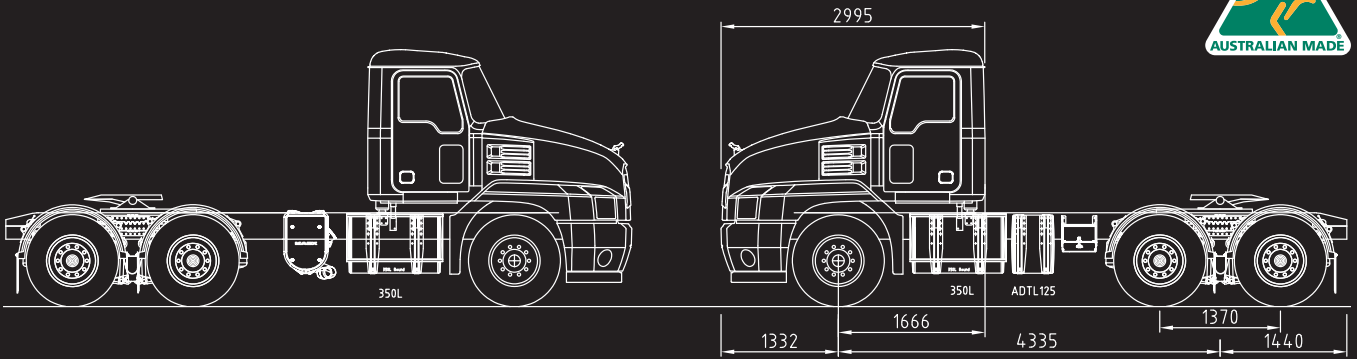

## MACK ANTHEM DAYCAB SINGLE TRAILER/A-DOUBLE FOR SINGLE AND A-DOUBLE TRAILER APPLICATIONS

### PURPOSE BUILT FOR REGIONAL HAUL

The Mack Anthem Daycab is spec'd ready to start work in both single trailer and A-Double distribution applications.

A spacious well-appointed cab provides the driver with a comfortable ergonomic work space. The Mack MP8 535hp engine coupled to the *m*DRIVE automated transmission and 2370B drive axles provide the performance and reliability to get the goods delivered on time, trip after trip. The Bendix Wingman driver assist systems aid the driver's awareness of potential hazards keeping both them and other road users safe. This specification will suit local and regional freight distribution applications.

FEATURE	BENEFIT
Mack 535hp MP8 Engine	<ul style="list-style-type: none"> <li>Fuel efficient operation</li> <li>Exceptional engine braking effect provided by the Mack PowerLeash Engine Brake</li> </ul>
Mack <i>m</i> DRIVE 12 Speed Direct Drive Transmission	<ul style="list-style-type: none"> <li>Fully integrated Mack driveline match, for improved efficiency and performance</li> <li>Reduced driver workload</li> <li>Improved fuel efficiency</li> <li>Transmission works with engine to deliver an exceptional &amp; class leading powertrain installation</li> </ul>
Daycab	<ul style="list-style-type: none"> <li>Large &amp; spacious interior</li> </ul>
Rear Axle Mack 2370B axles with 3.40 ratio	<ul style="list-style-type: none"> <li>Two single reduction, hypoid gears with great strength and quiet operation</li> <li>Three reliable differential locks, for high vehicle agility</li> <li>Unit, maintenance-free bearings for longer service life and easier servicing</li> </ul>
Rear Suspension Mack Air Ride Suspension	<ul style="list-style-type: none"> <li>High stability and good traction with tandem drive, even on loose and slippery surfaces</li> <li>Four bellows per axle reduces the risk of kick-back into the cab during driving</li> <li>Excellent handling and stable driving comfort</li> </ul>
Wheelbase 4335mm	<ul style="list-style-type: none"> <li>Ideal for application compatibility</li> </ul>
Rear Overhang 1440mm	<ul style="list-style-type: none"> <li>Short overhang improves trailer leg clearance</li> </ul>
Fuel Tank Capacity 700 litres	<ul style="list-style-type: none"> <li>1x350 litre LHS Round</li> <li>1x350 litre RHS Round</li> </ul>
AdBlue Capacity 125 litres	<ul style="list-style-type: none"> <li>1x125 litre RHS Round</li> </ul>
RH Low Underframe Exhaust	<ul style="list-style-type: none"> <li>Reduced weight</li> <li>Improves trailer swing clearance</li> </ul>

### WHY BUILT FOR PURPOSE IS GOOD FOR BUSINESS

Mack has been building trucks locally for over 50 years. During this time, we've come to know the specific demands of every sector in the transport industry. Now we've brought all our experience to bear, to offer models that have the ideal geometry and drive-line components for specific applications, straight off the assembly line.

For full spec and pricing, contact your local Mack Dealer.

